

LX1973B AMBIENT LIGHT DETECTOR

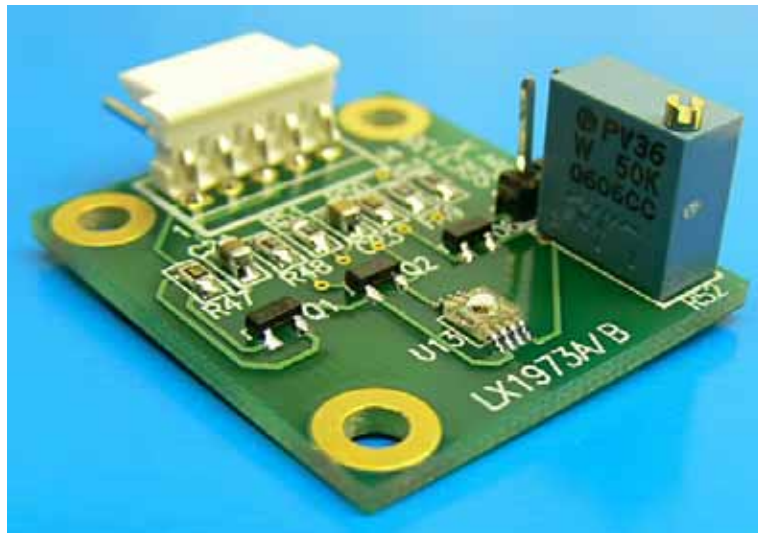

INTRODUCTION TO PRODUCT

The LX1973B Evaluation Board is available from Microsemi for evaluating the functionality and performance of the LX1973B ambient light sensor. The component sizes used on the evaluation board facilitate easy probing, however, in practice, smaller component sizes are recommended to minimize the circuit physical size.

KEY FEATURES

- Nearly Perfect *Best Eye*[™] Human Eye Spectral Response
- 25°C Dark Current <0.005 lux
- 5 Decades Compressed Output
- 10% Accuracy Over Temperature
- Very Low IR Sensitivity
- Highly Accurate & Repeatable Output Current vs. Light
- Scalable Output Voltage
- No Optical Filters Needed

APPLICATIONS

- Auto Headlamp Control
- Auto Mirror Contrast Control

PART SPECIFIC INFORMATION

Part Number	Product
LX1973BIPL	Ambient Light Detector, MSOP Standard Package
LX1973BIPR	Ambient Light Detector, MSOP Reverse Form Package

Table 1 - PART INFORMATION

IC	Evaluation Boards
LX1973BIPL	LX1973B EVAL KIT

Table 2 - EVALUATION BOARD INFORMATION

SCHEMATIC AND PCB LAYOUT FOR LXE

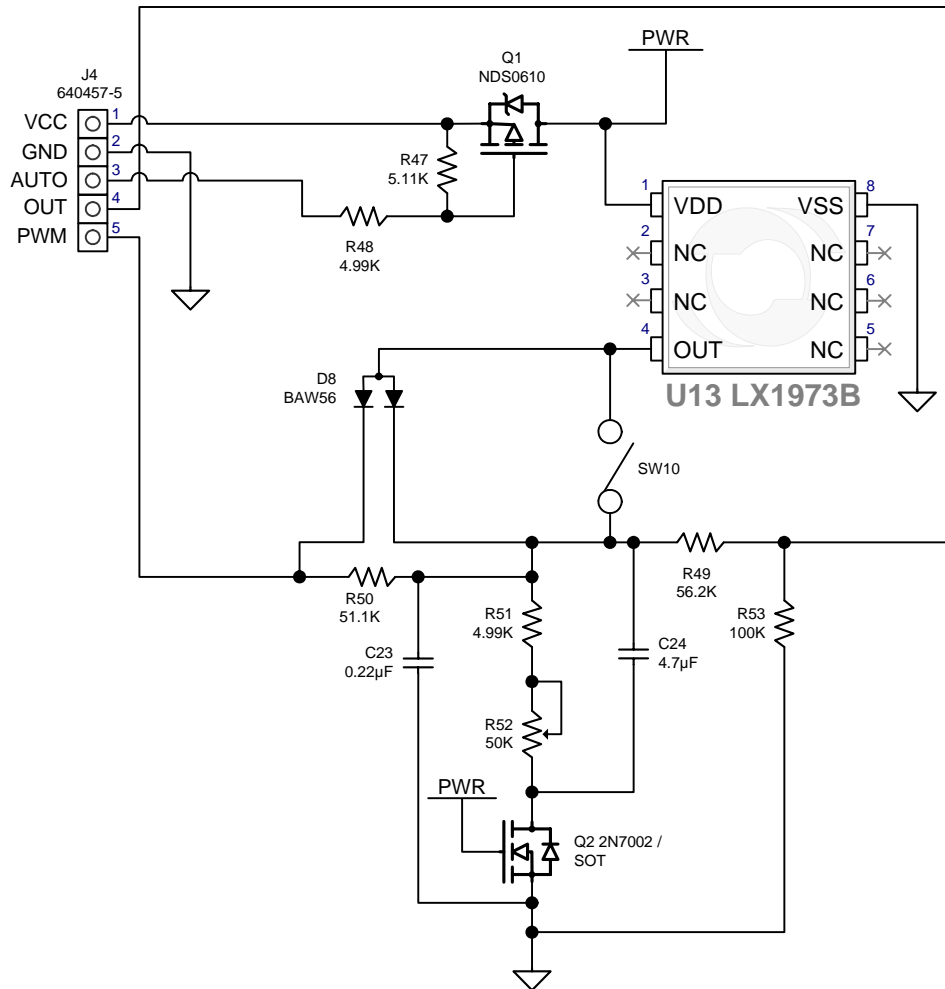

Figure 1 - LX1973B Evaluation Board Schematic

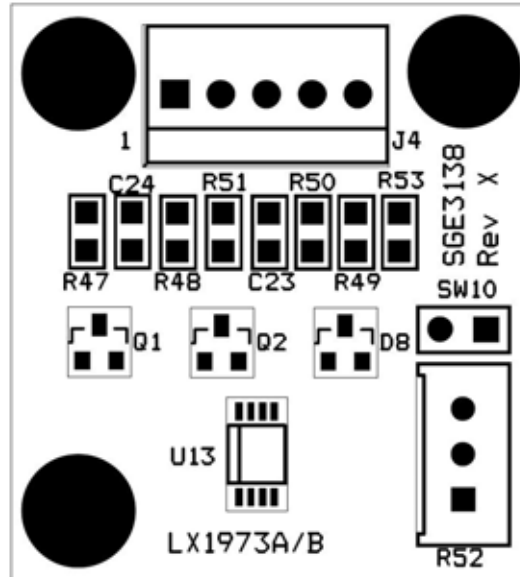

Figure 2 - LX1973B Evaluation Board PCB Layout

IC BLOCK DIAGRAM

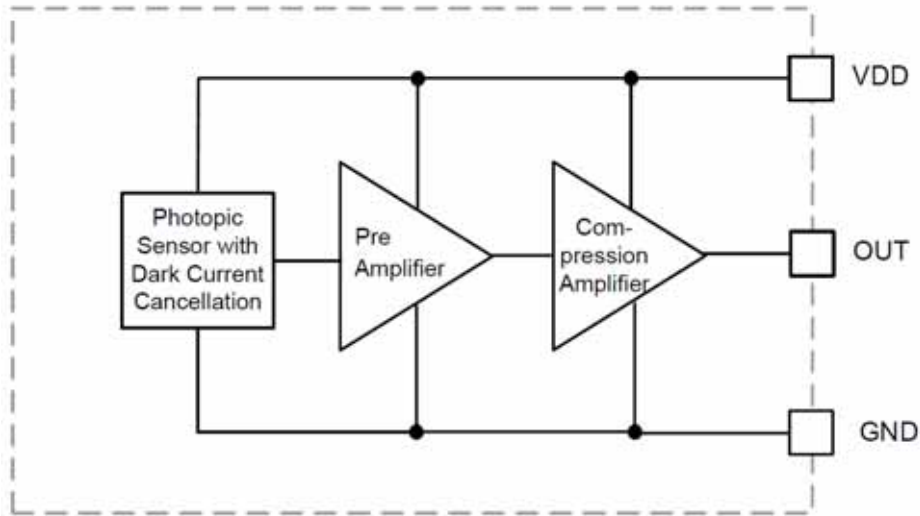

Figure 3 - Simplified Block Diagram

LX1973B EVAL BOARD

Schematic: The LX1973B Eval board schematic is shown in Figure 1.

PCB Layout: The LX1973B Eval board layout is shown in Figure 2.

Connections: The LX1973B Evaluation Board has a 5-pin connector connecting to outside power and signals. The connection pin names and functions are listed below. Figure 4 is a suggested test connection diagram.

Jumper Setting: Jumper SW10 is used to bypass the PWM effect, if you don't want to use PWM input, you can put the jumper cap on.

Pin #	Pin Name	Function
1	V _{CC}	+5V Power Supply
2	GND	Power Return
3	AUTO	Sensor On/Off Control
4	OUT	Sensor Output
5	PWM	PWM Input

Table 3 - Connector Pin Assignment

Basic Test Steps: The following is a demonstration scenario that can be used to evaluate the LX1973B.

- 1) Make connections as shown in Figure 4. Apply 5V power source to the board. Measure Pin 1 and Pin 2 on connector J4 by using multimeter (Red lead to pin 1, black lead to pin 2) to verify +5V power is supplied to the board.
- 2) Power on +3.3V to the AUTO pin to turn on the light sensor. The light sensor output should show on the scope. While observing the sensor output, power on / off the 3.3V. This demonstrates that the sensor output is controlled by the AUTO pin.
- 3) Change the light input (simply cover sensor with hand) while observing the scope, the waveform should change in conjunction with the light input change.
- 4) Change TRIMPOT R52 value can change the sensor output circuit sensitivity and scale. The smaller the R52 value, the larger range the light sensor can sense, and the lower sensitivity the circuit will be.
- 5) Connect +3V PWM signal to pin 5. Adjust PWM duty cycle while observing the sensor output. The output amplitude should change with the PWM duty cycle change.
- 6) When the PWM duty cycle is 100%, it is equal to a +3V power to pin 5. If a +3V (or +3.3V) voltage is connected to pin 5, it sets the minimum output voltage of the sensor.

Note: The LX1973A is very sensitive to light. Office lighting may saturate the device

LX1973B TYPICAL TEST HOOKUP

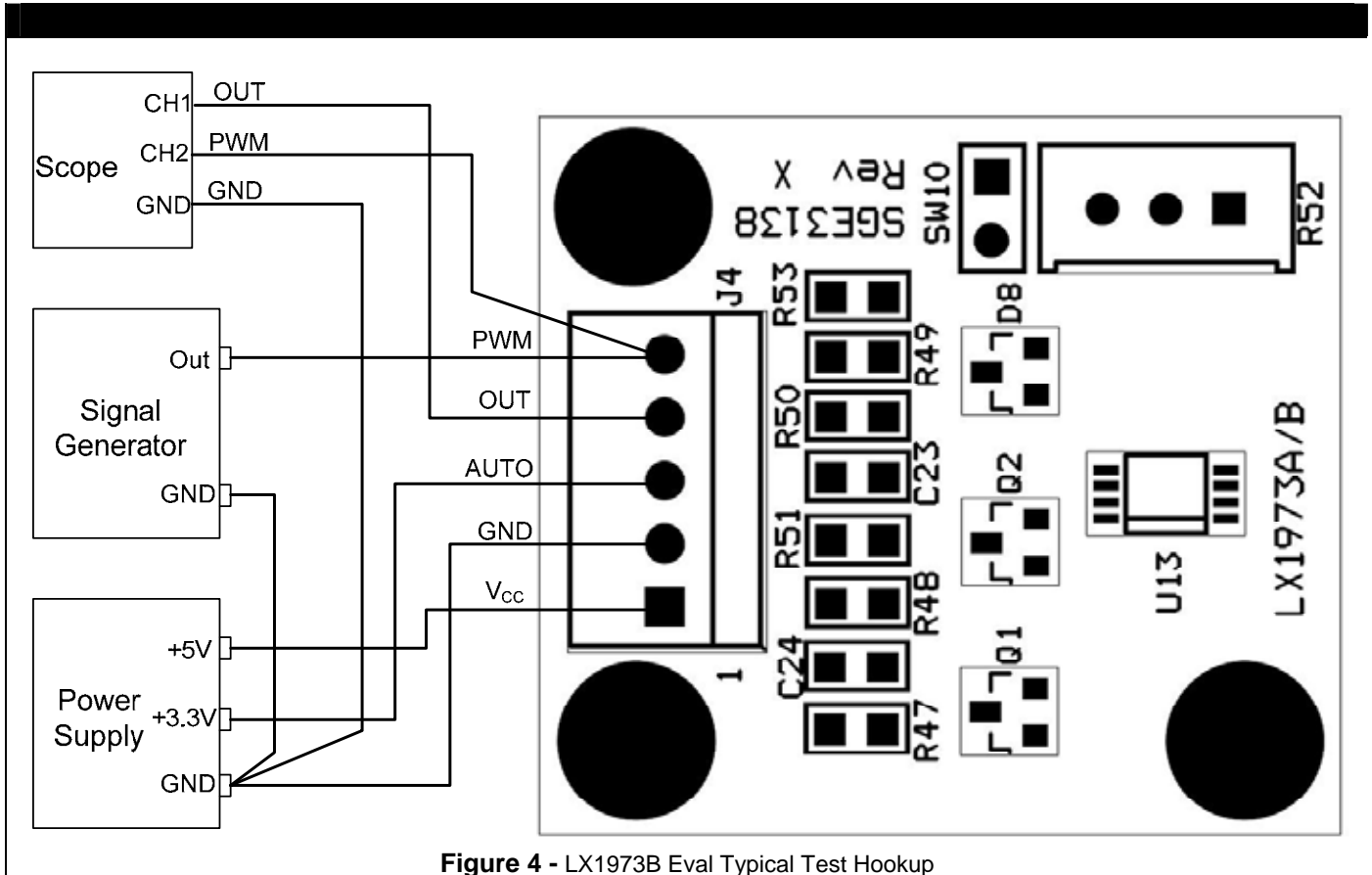

Figure 4 - LX1973B Eval Typical Test Hookup

LX1973B EVALUATION BOARD BILL OF MATERIALS

MISCELLANEOUS COMPONENTS

Line Item	Part Description	Manufacturer & Part #	Case	Reference Designators	Qty
1	Microsemi IC – Ambient Light Sensor	MICROSEMI LX1973BIPL	MSOP-8	U13	1
2	MOSFET P-CH 60V 120MA SOT-23	FAIRCHILD NDS0610	SOT-23	Q1	1
3	MOSFET N-CH 60V 300MA SOT-23	PHILIPS 2N7002 T/R	SOT-23	Q2	1
4	Trimpot Cerm 50K OHM 25TRN TOP	MURATA PV36W503C01B00	Through Hole	R52	1
5	Diode Schottky 30V 100MA	STMICROELECTRONICS BAR43AFILM	SOT-23	D8	1
6	Connector Header right angle 5POS .100	AMP 640457-5	Through Hole	J4	1

CAPACITORS

Line Item	Part Description	Part Description	Case	Reference Designators	Qty
1	Capacitor, 4.7µF, 16V, ±20%	PANASONIC ECJ-2FF1C475Z	0805	C24	1
2	Capacitor, 0.22µF, 16V, ±20%	PANASONIC ECJ-2VF1C224Z	0805	C23	1

RESISTORS

Line Item	Part Description	Part Description	Case	Reference Designators	Qty
1	Resistor, 5.11K, 1%, 1/8W	PANASONIC ERJ-6ENF5111V	0805	R47	1
2	Resistor, 4.99K, 1%, 1/8W	PANASONIC ERJ-6ENF4991V	0805	R48,51	2
3	Resistor, 10K, 1%, 1/8W	PANASONIC ERJ-6ENF1002V	0805	R49	1
4	Resistor, 51.1K, 1%, 1/8W	PANASONIC ERJ-6ENF5112V	0805	R50	1
5	Resistor, 100K, 1%, 1/8W	PANASONIC ERJ-6ENF1003V	0805	R53	1